



# **RC 44**

## **ONE DESIGN**

### **CLASS RULES 2016**



Effective Date : 20.03.2016

The RC 44 was designed in 2005 by Coutts Justin Design

# INDEX

---

## PART I – ADMINISTRATION

### Section A – General

A.1	Language .....	4
A.2	Abbreviations .....	4
A.3	Authorities .....	4
A.4	Administration of the class .....	4
A.5	ISAF rules .....	4
A.6	Class rules variations .....	5
A.7	Class rules amendments .....	5
A.8	Class rules interpretation .....	5
A.9	International class fee and ISAF building plaque .....	5
A.10	Sail numbers .....	5
A.11	Hull certification .....	5
A.12	Initial hull certification .....	5
A.13	Validity of certificate .....	6
A.14	Hull re-certification .....	6
A.15	Retention of certification documentation .....	6

### Section B – Boat eligibility

B.1	Class rules and certification .....	6
-----	-------------------------------------	---

## PART II – REQUIREMENTS AND LIMITATIONS

### Section C – Conditions for racing

C.1	General .....	7
C.2	Driver .....	7
C.3	Crew .....	7
C.4	Personal equipment .....	8
C.5	Advertising .....	9
C.6	Portable equipment .....	9
C.7	Boat .....	9
C.8	Hull .....	9
C.9	Hull appendages .....	10
C.10	Rig .....	10
C.11	Sails .....	12

### Section D– Hull

D.1	General .....	13
D.2	Assembled hull .....	14

### Section E – Hull appendages

E.1	Parts .....	15
E.2	General .....	15
E.3	Keel .....	15
E.4	Rudder blade, rudder stock and steering system .....	15

### Section F – Rig

F.1	Parts .....	16
F.2	General .....	16
F.3	Mast .....	17
F.4	Boom .....	17
F.5	Bowsprit .....	17
F.6	Standing rigging .....	18
F.7	Running rigging .....	18

### Section G – Sails

G.1	Parts .....	18
G.2	General .....	18
G.3	Mainsail .....	19
G.4	Headsails .....	19
G.5	Spinnaker .....	20

## PART III – APPENDICES

Appendix A - Sails .....	21
Appendix B – Hull dimensions and corrector weights, .....	23
Appendix C – Keel and rudder positions .....	25
Appendix D – Keel offsets .....	26
Appendix E – Rudder offsets .....	27
Appendix F – Rigging .....	28
Appendix G – Class insignia .....	28
Appendix H – Hardware and fittings... ..	29

# INTRODUCTION

---

*The RC 44 is a high performance one design racer, created for top level racing under these Class Rules in international regattas.*

*The RC 44 was designed by Coutts Justin Design as a light displacement high performance racer. The concept and the design features of the RC 44 are dedicated to enthusiastic amateur and professional sailors looking for high level racing.*

*The RC 44 is intended to be a support for amateur owners driving their boat in fleet racing series. It is also intended to be sailed for other type of races, including match racing series, exhibition races and/or team races.*

*The objective of these Class Rules is to keep the absolute one design aspect of the Class by ensuring that all boats are as identical as possible in terms of construction procedures, shape of hull and appendages, weight and weight distribution, deck layout and equipment, sail plan and performance.*

# PART I – ADMINISTRATION

---

## Section A – General

### A.1 LANGUAGE

- A.1.1 The official language of the Class is English and in case of dispute over translation the English text shall prevail.
- A.1.2 The word “shall” is mandatory and the word “may” is permissive.

### A.2 ABBREVIATIONS

- A.2.1 ISAF International Sailing Federation
- MNA ISAF Member National Authority
- CA RC 44 Class Association
- NCA National Class Association
- ERS Equipment Rules of Sailing
- RRS Racing Rules of Sailing
- CO RC 44 Class Office
- EC Executive Committee of the RC 44 Class Association
- CM Class Chief Measurer
- MF Measurement Form
- MC Measurement Certificate
- TC RC 44 Technical Committee

### A.3 AUTHORITIES

- A.3.1 The international authority of the Class is the Executive Committee of the RC 44 Class Association (EC).
- A.3.2 The Class Chief Measurer (CM) shall be appointed by the Executive Committee in cooperation with the Class Office (CO).
- A.3.3 Notwithstanding anything contained herein, the CM has the authority to withdraw a **certificate** and shall do so on the request of the ISAF.

### A.4 ADMINISTRATION OF THE CLASS\*

- A.4.1 ISAF has delegated its administrative functions of the Class to the EC. The EC shall delegate part or all of its functions, as stated in these **class rules**, to the CO, that may further delegate part or all of its functions to a NCA.

### A.5 ISAF RULES

- A.5.1 These **class rules** shall be read in conjunction with the ERS, except that section H.2.1 shall not apply.
- A.5.2 Except where used in headings, when a term is printed in “**bold**” the definition in the ERS applies and when a term is printed in “*italics*” the definition in the RRS applies.

### A.6 CLASS RULES VARIATIONS

- A.6.1 RRS and ISAF Regulations shall apply.

## **A.7 CLASS RULES AMENDMENTS**

- A.7.1 Amendments to these **class rules** are upon submission or subject to approval of CO and shall be voted by the EC and are subject to the approval of the ISAF in accordance with the ISAF Regulations. Only NCA, CM, EC and CO can initiate an amendment.

## **A.8 CLASS RULES INTERPRETATION**

- A.8.1 Interpretation of **class rules** shall be made by the CM upon consultation of the TC and in accordance with the ISAF Regulations.

## **A.9 INTERNATIONAL CLASS FEE AND ISAF BUILDING PLAQUE**

- A.9.1 The licensed hull builder shall pay the International Class Fee to the ISAF.
- A.9.2 ISAF shall, after having received the International Class Fee for the hull, send the ISAF Building Plaque and a measurement form to the licensed hull builder.

## **A.10 SAIL NUMBERS**

- A.10.1 Sail numbers shall be issued by the CO.
- A.10.2 Sail numbers may be issued in consecutive order starting at “1”, this official sail number being the hull number. At the discretion of the CO and according to the owner’s national regulations, the CO may deliver a sail number that is not related to the hull number.

## **A.11 CERTIFICATION**

- A.11.1 A **certificate** shall record the following information:
- (a) RC 44 Class Association
  - (b) **Certification authority (currently: CO)**
  - (c) Sail number issued by the CO
  - (d) Owner’s name and address
  - (e) Hull, appendages and spar serial numbers
  - (g) Hull weight and corrector weights (if any)
  - (h) Confirmation of RC 44 standard equipment list
  - (i) Builder / Manufacturers details
  - (f) Name and MNA of Official Measurer certifying the hull
  - (j) Date of issue of initial **measurement form**
  - (k) Date of issue of **certificate**

## **A.12 INITIAL HULL CERTIFICATION**

- A.12.1 For a **certificate** to be issued to hull not previously **certified**:
- (a) **Certification control** shall be carried out by an **official measurer** who shall complete the **measurement form (MF)**.
  - (b) The **measurement form** and the **certification** fee shall be sent to the **certification authority**.
  - (c) Upon receipt of a satisfactorily completed **measurement form** and **certification** fee, the **certification authority** will issue a **measurement certificate (MC)**. The **certification authority** shall send the original **measurement form** to the owner and register a copy with the CO. The **certification** fee amount shall be approved by the CO and may be reviewed each year by the EC.

## **A.13 VALIDITY OF CERTIFICATE**

A.13.1 A **certificate** becomes invalid upon:

- (a) The change to any items recorded on the hull **certificate** as required under A.11.
- (b) Withdrawal by the **certification authority**,
- (c) The issue of a new **certificate**,
- (d) Change of ownership.

## **A.14 HULL RE-CERTIFICATION**

A.14.1 The **certification authority** may issue a **certificate** to a previously certified boat:

- (a) When it is invalidated under A.13.1 (a) or (d), after receipt of the old **certificate**, and **certification** fee if required.
- (b) When it is invalidated under A.13.1 (b), at its discretion
- (c) In other cases, by application of the procedure in A.12.

## **A.15 RETENTION OF CERTIFICATION DOCUMENTATION**

A.15.1 The **certification authority** shall:

- (a) Retain a copy of the **measurement form** upon which the current **certificate** is based.
- (b) Upon request, transfer this documentation to the new **certification authority** if the hull is exported.

# **Section B – Boat Eligibility**

For a **boat** to be eligible for *racing*, it shall comply with the rules in this section.

## **B.1 CLASS RULES AND CERTIFICATION**

B.1.1 The boat shall:

- (a) Be in compliance with the **class rules**.
- (b) Have a valid **certificate**.
- (c) Have valid **certification marks** as required.

# PART II – REQUIREMENTS AND LIMITATIONS

---

The **crew** and the **boat** shall comply with the rules in Part II when *racing*. In case of conflict Section C shall prevail.

The rules in Part II are **closed class rules**. **Certification control** and **equipment inspection** shall be carried out in accordance with the ERS except where varied in this Part.

## Section C – Conditions for Racing

### C.1 GENERAL

#### C.1.1 RULES

- (a) The RRS shall apply.
- (b) The ERS Part I – Use of Equipment shall apply.

#### C.1.2 Alteration of the Rules of C1.1

- (a) Rule 42(a) will not apply.

### C.2 CREW

Whilst racing under these rules the ISAF Sailor Classification Code, Regulation 22, shall apply. All sailors requiring a classification should apply on the ISAF website [www.sailing.org](http://www.sailing.org). All Group 1 **crew** shall hold valid classifications. Unclassified sailors will be deemed to be Group 3.

#### C.2.1 LIMITATIONS

- (a) Whilst racing under these class rules the ISAF Sailor Classification Code, Regulation 22, will apply. The crew shall contain no more than 4 Group 3 sailors.
- (b) All Group 1 sailors shall hold valid classifications. Unclassified sailors will be deemed to be Group 3.
- (c) Whilst racing under these class rules the boat captains shall be considered ISAF Group 1 sailors. A boat captain is a person in charge of the maintenance, assembling and disassembling of the boat.
- (d) The CO may change the crew limitations for exhibition events or special events and shall mention this change in the notice of race.
- (e) For a full female crew only, the maximum crew weight will be 740 kg and the minimum number of Cat 1 sailors on boat shall be 3 (boat captain as per C.2.1.c not included).

#### C.2.2 WEIGHTS

When competing under these Class Rules, the total weight of the crew including driver (in at least swimwear and weighed individually) shall not exceed 680 kg.

#### C.2.3 HIKING

Hiking while racing is allowed with the following limitations:

- (a) Crew members can only use: sheets, car pullers, vang, winch, winch handles, shrouds or any existing line that is running rigging but not more than 200mm above the deck level.
- (b) Adding loop, lines or any other device to hike is not allowed.
- (c) Making loops on existing line is not allowed.

### C.2.3 HELMSMAN LIMITATIONS

The helmsman shall be designated an Owner, Substitute or Charter helmsman (the category).

In fleet racing series one Owner, Charter or Substitute helmsman shall steer the **boat** at all times. There is no driver limitation for formats other than fleet racing, including match races and exhibition races. These formats shall be approved by the CO.

The **boat** may be temporarily steered by other members of the **crew** in the case of an emergency involving the safety of the **boat** or **crew**.

### C.2.4 HELMSMAN APPROVAL

CO shall approve all helmsmen in accordance with the criteria set out below.

When competing in fleet races under these Class Rules, all boats shall be helmed by their owner or joint owners or a bona fide member of the RC 44 Class Association who has chartered a boat and meets the amateur owner driver requirements. In case he is not available, an owner may request to appoint a substitute driver. This request shall be made in written to the CO or CO Representative before the start of an event, together with a detailed professional and sailing CV of the potential substitute driver. The CO will then circulate the decision to the owners.

A list of all approved helmsmen and their designations will be published on the class association website ([www.rc44.com](http://www.rc44.com)).

An owner or charterer shall make his own application and may make an application for Substitute helmsman.

Any Owner may request a review of the eligibility of any helmsman by the CO.

### C.2.5. HELMSMAN CRITERIA

Subject to the above helmsmen shall be categorised and eligible as follows:

#### OWNER HELMSMAN

- (i) An owner helmsman is a sailor who owns 100% of a **boat**.
- (ii) Shall hold a valid Group 1 classification.
- (iii) Shall be members of the RC 44 Class Association and pay the annual membership fee

Approval of an Owner helmsman is valid throughout ownership provided there is no change in his circumstances that may materially alter the original application.

#### SUBSTITUTE HELMSMAN

- (i) A substitute helmsman shall hold a valid Group 1 classification.
- (ii) Shall not actively take part in an Olympic program.
- (iii) Shall be approved by the CO.

#### CHARTER HELMSMAN

- (i) A helmsman who is chartering a **boat** shall hold a valid Group 1 classification.
- (ii) Shall be member of the RC 44 Class Association and pay the annual membership fee
- (iii) A charter, other than one who already owns a RC 44, shall not charter a boat more than once. The Class Office may allow exceptions.

### **C.3 SPARE**

### **C.4 PERSONAL EQUIPMENT**

#### **C.4.1 MANDATORY**

- (a) The boat shall be equipped with **personal buoyancy** for each crew member to the minimum standard EN 393: 1995 (CE 50 N), or near equivalent. It is recommended that buoyancy as per ISAF Offshore Special Regulations - Appendix J: Category 5 for inshore races EN 396 ISO 12402 (150 N) be carried on board. Automatic inflatable **personal buoyancy** is not permitted, except where equipped with hydrostatic inflator system.
- (b) The owner, or the appointed skipper if the owner is not on board, is solely responsible to ensure that adequate **personal buoyancy** is available on board for each crew member including driver.
- (c) **Personal buoyancy** shall comply with national safety regulations applicable in the venue country or required by the Organising Authority in the notice of race.

### **C.5 ADVERTISING**

#### **C.5.1 LIMITATIONS**

Advertising shall only be displayed in accordance with ISAF Advertising Code – See ISAF Regulation 20.

### **C.6 PORTABLE EQUIPMENT**

#### **C.6.1 MANDATORY**

The boat shall be equipped to the minimum standard set out in the ISAF Offshore Special Regulations - Appendix J: Category 5, Part B (portable equipment):

- (a) One anchor and chain, the combined weight of which shall not be less than 15 kg. The minimum weight of the anchor shall be 9 kg.
- (b) One fire extinguisher. The fire extinguisher shall be regularly checked according to the builder's notice.
- (c) One bucket of stout construction with at least 9 litres capacity plus a lanyard.
- (d) One lifebuoy with a drogue. Marine grade retro-reflective tape shall be fitted.
- (e) One portable VHF.
- (f) One manual bilge pump.
- (g) One compass (RC 44 standard electronic compass is acceptable)
- (h) One 20 meter heaving line.
- (i) The boat shall depart the dockside with the tank full.

#### **C.6.2 OPTIONAL**

- (a) All moveable equipment including but not limited to tools, personal gear bags and spare equipment, but excluding sails, anchor kit and safety equipment shall have a maximum combined weight of not more than 100 kg.
- (b) 3 litres of drinking water for each crew member. This shall not be included in the portable equipment weight limit.

### **C.7 BOAT**

#### **C.7.1 DIMENSIONS**

The dimensions of the **boat** shall be measured and shall be within the tolerances shown in the attached appendices and in the building specifications.

## C.7.2 WEIGHT

	minimum	maximum
The weight of the <b>boat</b> in dry condition	3650 kg	-
The weight of the <b>boat</b> in racing condition	3710 kg	

The weight shall be taken with complete hull (scoop and bow fitted) including all equipment and engine, all appendages, all spars, fixed running rigging and all liquids (full tank and full hydraulic circuit) and excluding **sails**, sheets and all portable equipment as listed in C.4 and C.6.

*Before weighing, see technical note in RC 44 - Measurement Manual. & RC44 boat weight policy 2012.*

## C.7.3 CORRECTOR WEIGHTS

- (a) One or more pairs of **corrector weights** of equal weight, made of lead, shall be permanently fastened to the liners in one forward and one aft area in the bilge (positioned as shown and according to the table in Appendix B.2) when the **boat** weight is less than the minimum requirement stated in C.7.2. The weight of the **corrector weights** has to be visibly punched.
- (b) The total weight of such **corrector weights** shall not exceed 60 kg.

## C.8 HULL

### C.8.1 MODIFICATIONS, MAINTENANCE AND REPAIR

- (a) The hull shape shall comply with the drawing detailed in Appendix B.
- (b) No modifications are permitted to the hull external surface and in particular no filling is permitted on any exterior surface of the hull or appendages, with the exception of routine maintenance, which includes antifouling application, painting and minor repairs,
- (c) All repairs requiring the use of filler or composite materials shall be reported to CO and approved by the CM.
- (d) No holes shall be drilled in the hull.
- (e) No additional equipment shall be fitted on the hull except as listed in the equipment list and provided by the Licensed Builders and Suppliers.

### C.8.2 FITTINGS

- (a) The deck hardware and winches fitted on every **boat** as standard is detailed in Appendix H. The equipment shall be maintained and serviced according to the suppliers specifications.
- (b) The removable stern scoop and the removable bow cone are standard parts of the hull. Hull or complete hull means the hull central part fitted with stern scoop and bow cone.

### C.8.3 LIMITATIONS

- (a) Any broken or non functional item shall only be replaced with an approved item. The CO records the latest version of the approved equipment list, in cooperation with Coutts Justin Design and the Licensed Builders and Suppliers.

## **C.9 HULL APPENDAGES**

### **C.9.1 MODIFICATIONS, MAINTENANCE AND REPAIR**

- (a) No modifications are permitted to the appendages and in particular no filling is permitted, with the exception of routine maintenance which includes antifouling application, painting and minor repairs.
- (b) No holes shall be drilled in the appendages.
- (c) No additional equipment shall be fitted on the appendages except as listed in the equipment list and provided by the Licensed Builders and Suppliers.

### **C.9.2 FITTINGS**

- (a) The trim tab fixed on the trailing edge of the keel fin shall comply with Appendix H.
- (b) The optional weed cutter device fixed to the leading edge of the keel fin shall comply with Appendix H.

### **C.9.3 KEEL**

- (a) The keel shall be made of a lead bulb fixed on a carbon fibre fin. The shape of the fin and the shape and weight of the bulb shall comply with Appendix D

### **C.9.4 RUDDER**

- (a) The shape and weight of the rudder blade shall comply with Appendix E.

## **C.10 RIG**

### **C.10.1 WEIGHT**

The weight of the parts of the **rig**, see F.3.5, shall be taken with complete mast or boom tube, fittings (screws, mast foot, spreaders and others) and excluding running rigging and removable instrument bracket (see RC 44 Measurement Manual).

### **C.10.2 CORRECTOR WEIGHTS**

- (a) If the weight of the **mast** does not comply with the minimum detailed in rule C.10.1 and F.3.5, one or more corrector weights (MCW), made of lead, and shall be added to meet the mast minimum weight and the minimum mast centre of gravity (COG) distance from the **mast datum point** (MDP).
- (b) The MCW may be added at any location on the mast, provided that they are permanently fastened. The weight of such MCW shall be visibly punched.

### **C.10.3 MODIFICATIONS, MAINTENANCE AND REPAIR**

- (a) Any broken, deteriorated or non functional item shall only be replaced with an approved item according to the list in Appendix H.
- (b) No holes shall be drilled in the spars.
- (c) No additional equipment shall be fitted on the spars except as listed in the equipment list and provided by the Licensed Builders and Suppliers.

### **C.10.2 FITTINGS**

- (a) The mast and rigging listed in Appendix F is fitted on every boat as standard. The equipment shall be maintained and serviced according to the suppliers specifications.

### C.10.3 LIMITATIONS

- (a) No more than one complete spar kit shall be paired with any one hull. If a spar is broken or damaged beyond repair, a replacement spar may be requested through the CO.
- (b) The spar kit shall remain a clear carbon finish.

### C.10.4 MAST

#### (a) DIMENSIONS

	minimum	maximum
<b>Limit mark width</b>	40 mm	-
<b>Upper point height (P)</b>	-	17 542 mm
<b>Lower point height (E) above sheer line</b>	1 780 mm	1 820 mm
<b>The lower point is the mast datum point</b>		

### C.10.5 BOOM

#### (a) DIMENSIONS

	minimum	maximum
<b>Limit mark width</b>	40 mm	-
<b>Outer point distance</b>		5430 mm

### C.10.6 RETRACTING BOWSPRIT

- (a) The bowsprit shall be fully retracted at all times other than when the spinnaker is set or in the act of being set or recovered.
- (b) The inner limit mark should not be outside the vertical line of the bow when the spinnaker is set.

	minimum	maximum
<b>Inner limit mark width</b>	25 mm	-
<b>Bowsprit point distance</b>		1980 mm

### C.10.7 STANDING RIGGING

- (a) Rigging links and rigging screws shall not be adjusted whilst racing.
- (b) Checkstays can be tuned anytime whilst racing.

## C.11 SAILS

### C.11.1 MODIFICATIONS, MAINTENANCE AND REPAIR

- (a) During an RC 44 Class series **sails** shall not be altered in any way except as permitted by these **class rules**.
- (b) During an RC 44 Class series the **equipment inspector** or the CO Representative shall be notified of any **sail** requiring repair.
- (c) If a sail is damaged beyond repair, it may be replaced with a new sail. Application shall be made to the **equipment inspector** (or the CO Representative) for a replacement sail. Application for a replacement Sail Sticker can be made only for a

sail produced and with a sail sticker of the current year (January 1<sup>st</sup> to December 31<sup>st</sup>). No replacement sticker shall be delivered for a sail produced and registered prior to the year when damage beyond repair occurs.

- (d) All sails declared for an RC 44 Class event may be inspected and shall have a numbered Class Association Sail Sticker. Stickers shall not be transferred from one sail to another.
- (e) An **official measurer** shall measure and certify all sails, see G.2.2. (a).

#### C.11.2 LIMITATIONS

- (a) The full following inventory: (1) mainsail, one (1) genoa 1, one (1) genoa 2, one (1) genoa 3 and two (2) spinnakers, shall be declared and carried aboard whilst racing, for each event.
- (b) An owner with more than one boat may not transfer sail inventories. A Class Member who charters is permitted to transfer his own sails to the chartered boat.
- (c) A new owner who acquires an RC 44 may purchase a base inventory of maximum eight (8) sail stickers in the first calendar year (January 1 – December 31). An existing owner is permitted six (6) new stickers per calendar year (January 1-December 31). Sails must be constructed and stickers applied by the end of the calendar year. Stickers not purchased will not accrue in the following year
- (d) C.11.2 (c) applies to a Class member who is not a boat owner and charters an RC 44.

#### C.11.3 MAINSAIL

##### (a) IDENTIFICATION

The national letters and sail numbers shall comply with the RRS except where prescribed otherwise in these **class rules**.

##### (b) USE

- (1) The **sail** shall be hoisted on a halyard. The arrangement shall permit hoisting and lowering of the **sail** whilst afloat.
- (2) **Luff** bolt ropes shall be in the **spar** grooves.

#### C.11.4 HEADSAILS

##### (a) USE

When in use a headsail shall be attached to the tack fitting, its luff shall be attached to the headstay with soft hanks and the sail shall be sheeted through the headsail cars.

## Section D – Hull

### D.1 GENERAL

#### D.1.1 RULES

- (a) The **hull**, including the hull weight, shall comply with the **class rules** in force at the time of initial **certification**.

#### D.1.2 CERTIFICATION

See Rule A.13.

#### D.1.3 MODIFICATIONS, MAINTENANCE AND REPAIR

- (a) The hull shell, deck, bulkheads shall not be altered in any way except as permitted by these **class rules**.

- (b) Routine maintenance such as painting and polishing is permitted without re-certification.
- (c) If any hull moulding is repaired in any other way than described in C 8.1 an **official measurer** shall verify that the external shape is the same as before the repair and that no substantial stiffness, or other advantage has been gained as a result of the repair. The **official measurer** shall also describe the details of the repair on the **measurement form**.

#### D.1.4 DEFINITIONS

##### (a) HULL DATUM POINT

The **hull datum point** FMP1 is specified in Appendix B.

#### D.1.5 IDENTIFICATION

- (a) The hull shall carry the ISAF plaque permanently placed on the starboard side of the transom.

#### D.1.6 BUILDERS

- (a) The boat is produced by a limited number of Licensed Builders who are required to adhere to the same building procedures specified by Coutts Justin Design.
- (b) The rig and bowsprit shall be built by a builder licensed by Coutts Justin Design
- (c) All moulds shall be approved by Coutts Justin Design and ISAF.

## D.2 ASSEMBLED HULL

#### D.2.1 CONSTRUCTION

- (a) The boat shall be built only by Licensed Builders strictly according to the construction documentation issued by Coutts Justin Design and approved by Germanischer Lloyd.

#### D.2.2 FITTINGS

##### (a) MANDATORY

The deck hardware and winches according to the list in Appendix H is fitted on every boat as standard. Any broken or non functional item shall only be replaced with an identical item.

#### D.2.3 DIMENSIONS

- (a) The keel line shall be taken as the intersection line from transom to stem of the hull shell and the **hull** centerplane.
- (b) The sections shall be taken as vertical, transverse planes at the positions detailed in Appendix B

#### D.2.4 PROPULSION SYSTEM

- (a) The propulsion system according to the list in Appendix H is fitted on every boat as standard.
- (b) Any broken, deteriorated or non functional item shall only be replaced with identical according to the engine equipment list.
- (c) The location of the propulsion system shall only be positioned as shown on the official plans issued by Coutts Justin Design. Section E – Hull Appendages.

## Section E – Hull appendages

### E.1 PARTS

- (a) **Keel fin**, including **trim tab**.
- (b) **Rudder**

### E.2 GENERAL

#### E.2.1 RULES

- (a) **Hull appendages** shall comply with the **class rules** in force at the time of **certification**.
- (b) The **hull appendages** shall be made by licensed manufacturers approved by Coutts Justin Design.

#### E.2.2 MODIFICATIONS, MAINTENANCE AND REPAIR

- (a) Hull appendages shall not be altered in any way except as permitted by these **class rules**.
- (b) Routine maintenance such as antifouling application, painting and minor repairs is permitted without re-certification.
- (c) No painting shall be applied on the builder's sticker displaying the item serial number.

#### E.2.3 CERTIFICATION

- (a) The **official measurer** shall **certify hull appendages**.
- (b) The CO may appoint one or more persons at a licensed manufacturer to measure and **certify hull appendages** produced by that manufacturer in accordance with the ISAF In-house Certification Guidelines.

### E.3 KEEL

#### E.3.1 RULES

- (a) Rules in E.2. apply.

#### E.3.2 MATERIALS

- (a) The **keel fin** shall be of carbon fibre.
- (b) The bulb shall be of lead and meet the lead - antimonium specifications approved by Coutts Justin Design.

#### E.3.4 FITTINGS

- (a) MANDATORY
  - (1) **Trim tab**

#### E.3.5 DIMENSIONS

The bulb and the **keel fin** shall comply with the measurements shown in Appendix C and D

#### E.3.6 BULB AND FIN WEIGHT

- |  |         |
|--|---------|
| (a) Bulb weight including coating              | maximum |
|  | 2095 kg |
| (b) Fin weight including fittings and trim tab | 132 kg  |

- E.3.7 TRIM TAB DEFINITION
- (a) The maximum length of the trim tab slider is 870 mm (from end stopper to end stopper).
  - (b) Attachment on trim tab lever arm: minimum 700mm from pivot point.

## **E.4 RUDDER BLADE, RUDDER STOCK AND STEERING SYSTEM**

### **E.4.1 RULES**

- (a) Rules in E.2. apply.

### **E.4.2 MATERIALS**

- (a) The **rudder** blade and stock shall be made in accordance with the manufacturer's specifications.
- (b) The steering system according to the list in Appendix H is fitted on every boat as standard.
  - (i) The equipment shall be maintained and serviced according to the producers specifications.
  - (ii) Any broken, deteriorated or non functional item shall only be replaced with identical according to the equipment list.
  - (iii) If any item is no longer available the CM shall be consulted before replacement. The CO records that latest list of permitted items.

### **E.4.3 CONSTRUCTION**

- (a) The **rudder** blade shall be manufactured in a mould approved by Coutts Justin Design.

### **E.4.4 DIMENSIONS**

- (a) The overall rudder height, measured from the hull centreline at the aft upper corner of the rudder to the blade tip shall be  $2013 \pm 5$  mm (see Appendix E.1.1).
- (b) The rudder shall comply with the measurements shown in Appendix C and E.
- (c) The rudder weight fitted with Jeffa bearing sleeves is  $27 \pm 1.5$  kg.

## **Section F – Rig**

### **F.1 PARTS**

#### **F.1.1 MANDATORY**

- (a) **Mast**
- (b) **Boom**
- (c) **Bowsprit**
- (d) Standing **rigging**
- (e) Running **rigging**

### **F.2 GENERAL**

#### **F.2.1 RULES**

- (a) The **spars** and their fittings shall comply with the **class rules** in force at the time of **certification** of the **spar**.
- (b) The standing and running **rigging** shall comply with the **class rules**.

#### **F.2.2 MODIFICATIONS, MAINTENANCE AND REPAIR**

- (a) **Spars** shall not be altered in any way except as permitted by these **class rules**.

F.2.3 CERTIFICATION

(a) The **official measurer** shall **certify spars**.

F.2.4 DEFINITIONS

(a) MAST DATUM POINT

The **mast datum point** (MDP) is defined in C.10.4.

F.2.5 MANUFACTURER

(a) The rig shall be built by a licensed builder approved by Coutts Justin Design.

**F.3 MAST**

F.3.1 MATERIALS

(a) The **spar** shall be of carbon fibre.

F.3.2 CONSTRUCTION

(a) The mast **spar** shall be built as per the manufacturer's specifications.

F.3.3 FITTINGS

(a) MANDATORY

See list in Appendix H.

F.3.4 DIMENSIONS

The dimensions shall be as per the manufacturer's specifications and as recorded in the Measurement Form, measured as pointed out in the RC 44 Measurement Manual.

F.3.5 MAST WEIGHT AND CENTRE OF GRAVITY

(a) <b>Mast weight</b>	minimum	138 kg
	maximum	144 kg
(b) Mast centre of gravity from MDP	minimum	6200 mm

**F.4 BOOM**

F.4.1 MATERIALS

(a) The **spar** shall be of carbon fibre.

F.4.2 CONSTRUCTION

(a) The boom **spar** shall be built as per the manufacturer's specifications.

F.4.3 FITTINGS

(a) MANDATORY

One custom carbon rigid vang with internal purchase, min. Weight: 3kg

F.4.5 DIMENSIONS

Dimensions shall be as per the manufacturer's specifications and as stated in the Measurement Form.

F.4.6 BOOM WEIGHT

(a) <b>Boom weight</b>	minimum	25 kg
------------------------	---------	-------

**F.5 BOWSPRIT**

F.5.1 MATERIALS

(a) The **spar** shall be of carbon fibres.

- F.5.2 CONSTRUCTION  
 (a) Construction shall be as per the manufacturer's specifications.
- F.5.3 FITTINGS  
 (a) Stainless Steel tube tack line bowsprit end fitting.
- F.5.4 DIMENSIONS  
 Dimensions shall be as per the manufacturer's specifications and as stated in the Measurement Form.  
 Sectional dimension at **Inner Point**: min 80 x 100 mm
- F.5.5 BOWSPRIT WEIGHT  
 (a) **Bowsprit weight** minimum 7 kg

## F.6 STANDING RIGGING

- F.6.1 MATERIALS  
 (a) The standing **rigging** shall be as per the manufacturer's specifications.
- F.6.2 CONSTRUCTION  
 (a) MANDATORY  
 See list of fittings in Appendix H.
- F.6.3 FITTINGS  
 (a) Fittings shall be as supplied by the manufacturer.

## F.7 RUNNING RIGGING

- F.7.1 MATERIALS  
 (a) Materials are as per the list in Appendix H.  
 (b) Diameter is mandatory whereas length is recommended.
- F.7.2 FITTINGS  
 (a) Fittings shall be as supplied by the manufacturer.

## Section G – Sails (see also appendix A.1 to A.3)

### G.1 PARTS

- G.1.1 MANDATORY  
 (a) Mainsail  
 (b) Headsail  
 (c) Spinnaker

### G.2 GENERAL

- G.2.1 RULES  
 (a) **Sails** shall comply with the **class rules**.
- G.2.2 CERTIFICATION  
 (a) The **official measurer** shall **certify** mainsails, headsails and spinnakers near the starboard side of the tack. The **official measurer** shall sign and date the **certification mark**.  
 (b) The ISAF or an MNA may appoint one or more **In-House Official Measurers** to measure and **certify sails** produced by that manufacturer.

G.2.3 SAILMAKER

- (a) No licence is required.
- (b) The production date shall be indelibly marked near the **head point** by the sailmaker together with his signature or stamp.

**G.3 MAINSAIL**

G.3.1 CLASS INSIGNIA AND IDENTIFICATION

- (a) The class insignia shall conform with the dimensions and requirements as detailed in the diagram contained in Appendix G.1.a and be placed in accordance with Appendix G.1.b.
- (b) The national letters and sail numbers shall be according to RRS 77, Appendix G, except where varied herein. The national letters and sail numbers shall be positioned on both sides of the mainsail, centered between the third and fourth batten from the foot of the sail, with the starboard side being higher. In accordance with RRS 77, Appendix G5, the national letters and sail numbers are optional on the spinnaker.

.....	Minimum
1. Height	500mm
2. Thickness:	80mm
3. Width (excluding number one and letter l) :	300mm
4. Minimum space between adjoining or opposite characters, or edge of sail:	100mm

G.3.2 MATERIALS

- (a) The **ply** and **ply** fibres may consist of any material.
- (b) **Sail reinforcement** may consist of any material

G.3.3 CONSTRUCTION

- (a) The construction shall be: **soft sail**.
- (b) The dimensions of the mainsail are specified in G.3.4 and in Appendix A.1.
- (c) The batten **pockets** position is specified in the diagram contained in Appendix A.1. Tolerance is +/- 50mm.
- (d) The sail may be constructed so that it can be reefed.
- (e) Apart from restrictions mentioned above, the fittings and items attached to the sail are not limited.

G.3.4 DIMENSIONS

	min.	maximum
See drawing in appendix A		
Width at point on leech 2835 mm from <b>head point</b>		2785 mm
Width at point on leech 3375 mm from <b>head point</b>	-	3070 mm
Width at point on leech 5250 mm from <b>head point</b>	-	3660 mm
Width at point on leech 7815 mm from <b>head point</b>	-	4165 mm
Width at point on leech 11140 mm from <b>head point</b>	-	4705 mm
<b>Aft head point</b> from point 2000 mm on luff below <b>head Pt.</b>	-	3250 mm
Top width (measured along the sail)	2450	2500 mm
Leech length	-	17980 mm
Batten #2 (short batten) – <b>batten pocket</b> inside length		2030 mm

No convex curve on top of the mainsail.

## G.4 HEADSAILS

### G.4.1 MATERIALS

- (a) The **ply** and **ply** fibres may consist of any material.
- (b) **Sail reinforcement** may consist of any material.
- (c) Sail **batten** may consist of any material.

### G.4.2 CONSTRUCTION

- (a) The construction shall be: **soft sail**.
- (b) No battens are permitted for #1 Genoa.
- (c) 4 battens are permitted for #2 and #3 Genoas.
- (d) Use of PBO is not permitted.
- (e) Apart from restrictions mentioned above, the parts and items attached to the genoas are not limited.
- (f) The leech of #1 Genoa shall not have a convex curve.

### G.4.3 DIMENSIONS

See Appendix A.2.

Dimension	#1 Genoa	#2 Genoa	#3 Genoa
	maximum	maximum	maximum
<b>Luff length</b>	17 350 mm	17 300 mm	15 600 mm
<b>Clew Point to Luff (LP)</b>	6 900 mm	5 350 mm	5 100 mm
<b>Top width</b>	100 mm	90 mm	90 mm

**Foot irregularity:** max 50 mm

## G.5 SPINNAKER

### G.5.1 MATERIALS

- (a) The **ply** may consist of any materials.
- (b) **Sail reinforcement** may consist of any materials.

### G.5.2 CONSTRUCTION

- (a) The construction shall be: **soft sail**.
- (b) Apart from restrictions mentioned above, the parts and items attached to the spinnaker are not limited.

### G.5.3 DIMENSIONS

See Appendix A.3.

	maximum
<b>Luff length</b>	21 200 mm
<b>Leech length</b>	19 000 mm
<b>Foot length</b>	11 500 mm

No convex curve on top of the mainsail, top batten pocket inside of mainsail diagram, all battens removed for measurement. Widths (girths) are maxima. Girth at batten #7 is not part of the fundamental measurement.

## PART III – APPENDICES

The rules in Part III are **closed class rules**. Measurement shall be carried out in accordance with the ERS except where varied in this part.

### Appendix A

#### A.1 MAIN SAIL DIAGRAM

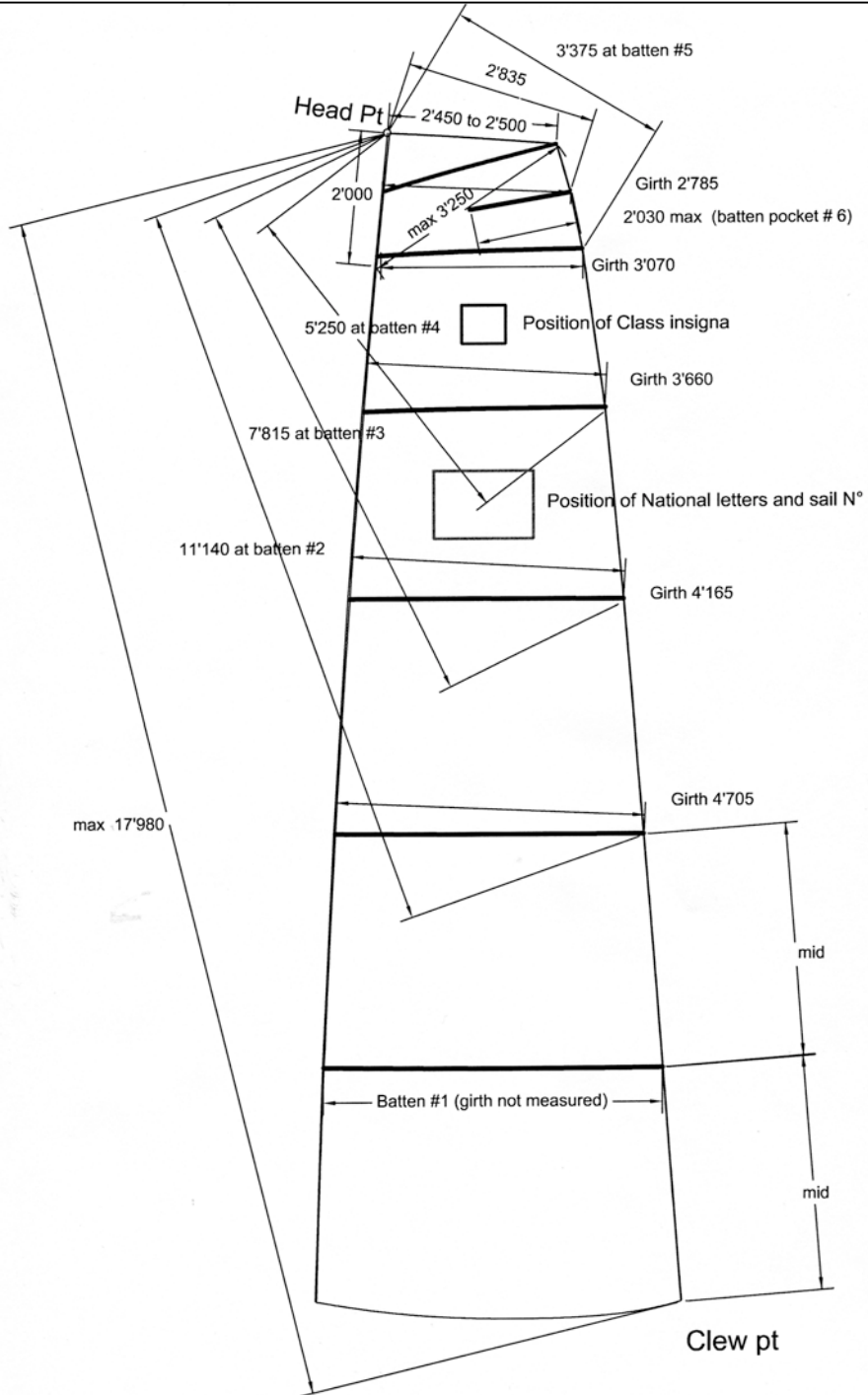
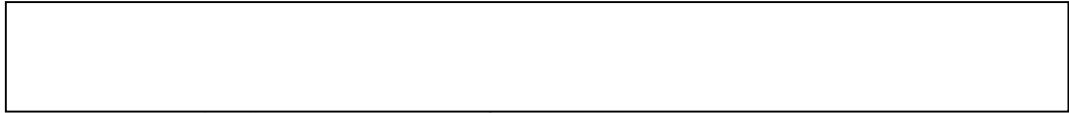

## A.2 HEAD SAIL DIAGRAM

and

## A.3 SPINNAKER

Leech :  
19 000  
mm max

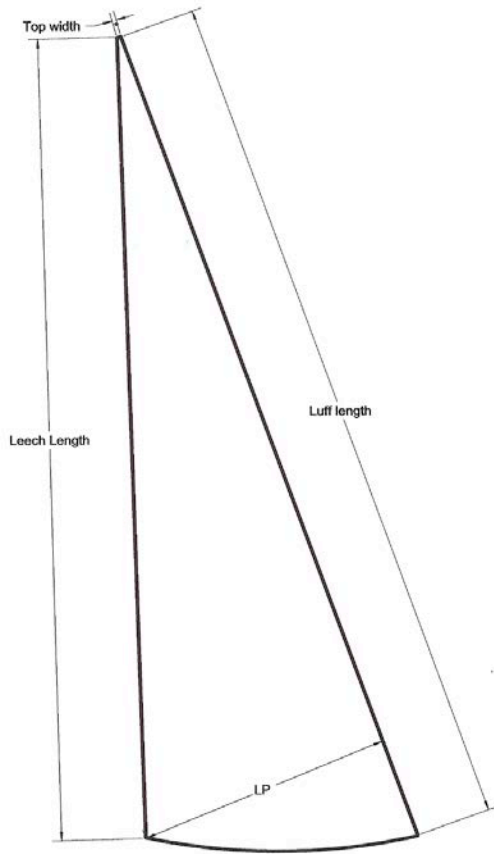

**Faltan parámetros necesarios o son incorrectos.**

# Appendix B

## HULL, CORRECTOR WEIGHTS, FITTINGS AND ELECTRONICS

### B.1 HULL DIMENSIONS

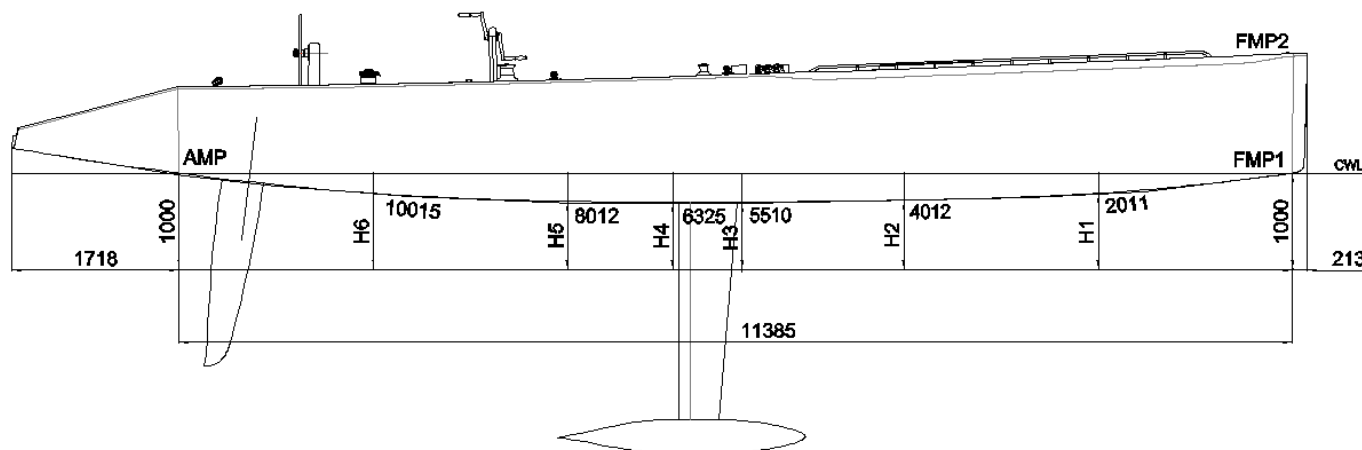

#### B.1.1 HULL DIAGRAM

#### B.1.2 HULL DATUM POINT

The hull datum point FMP1 is the intersection of the hull-crash bow joint line and the hull centreline (see drawing above).

#### B.1.3 TOLERANCES

- (a) The Licensed Builder shall record the height from base line of 6 points on the hull centreline as H1, H2, H3, H4, H5 and H6 as shown on the drawing. The heights shall be within the tolerances in Table A-B.

Methods of measurement see RC 44 Measurement Manual.

Station	Min.		Max.	Measured along hull keel line
( H0 at FMP1		1000		0
) H 1	793		803	2 011
T H 2	725		735	4 012
a H 3	703		713	5 510
b H 4	703		713	6 325
l H 5	727		737	8 012
e H7 at AMP		1000		11415 ± 10

A-B: all dimensions are in mm.

- (c) Hull length (HL) between FMP1 and AMP, parallel to base line:  
 min.: 11380 mm;      max.: 11400 mm

#### B.1.4 BOW, SCOOP & FIN FAIRING

- It is allowed to adjust crash bow, scoop, fin top and fin bottom. The joint should be clearly visible.
- No fairing is allowed across joints.

- It is not allowed to put any kind of tape across the joint.
- Crashbow cannot be glued on hull, measurer can ask for evidence that crashbow can be removed without causing any damage.

## B.2 CORRECTOR WEIGHTS POSITIONS AND WEIGHTS

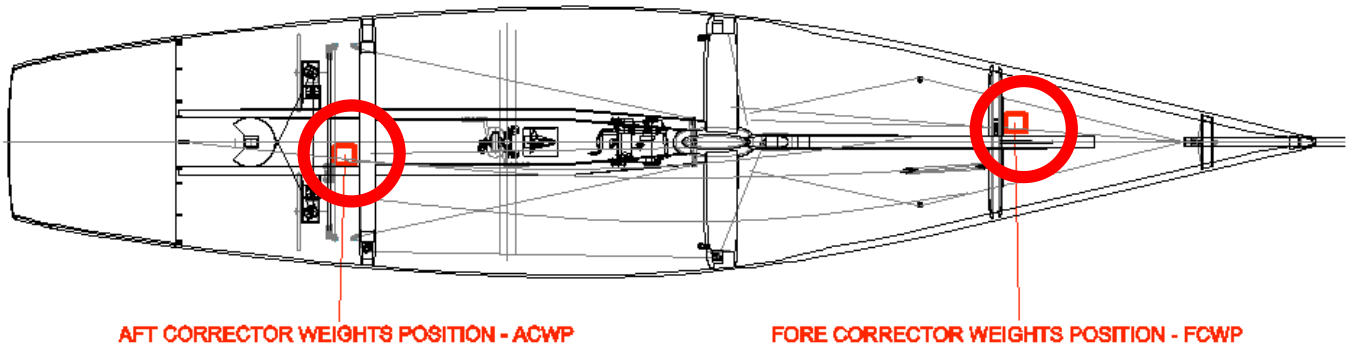

The pair(s) of corrector weights calculated in accordance with rule C.7.3 shall be positioned and permanently fastened to the liner.

# Appendix C

## C.1 KEEL AND RUDDER POSITION

### C.1.1 KEEL AND RUDDER POSITION DIAGRAM

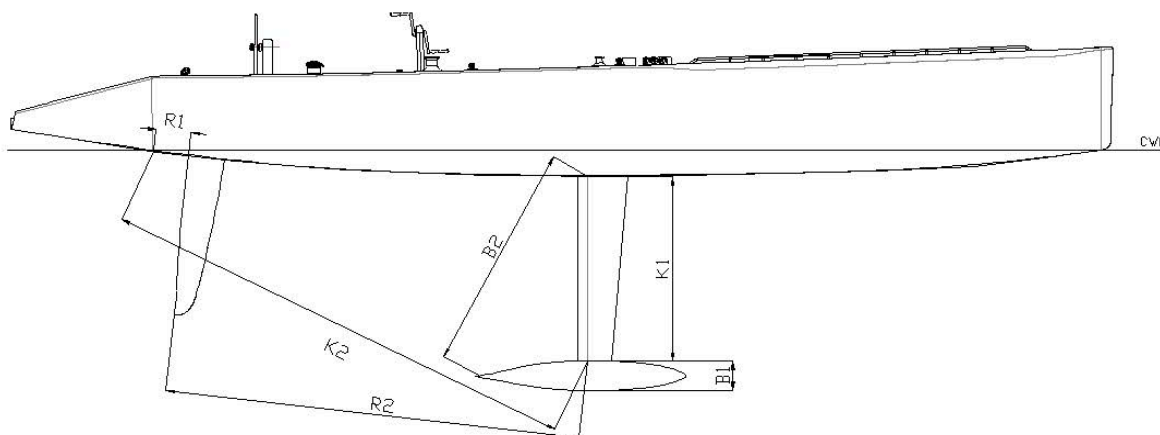

### C.1.2 TOLERANCES

- (a) The keel shall be located in accordance with the diagram below in accordance within the tolerances as per Table A-C
- (b) Table A-C: all dimensions are in mm.

	Min.	Max.
K1	2225	2235
K2	5822	5842
B1	350	354
B2	2772	2782
R1	442	452
R2	5045	5085

## Appendix D

### D.1 KEEL FIN AND BULB

#### D.1.1 KEEL DIAGRAM + LOCATION OF THE TEMPLATES

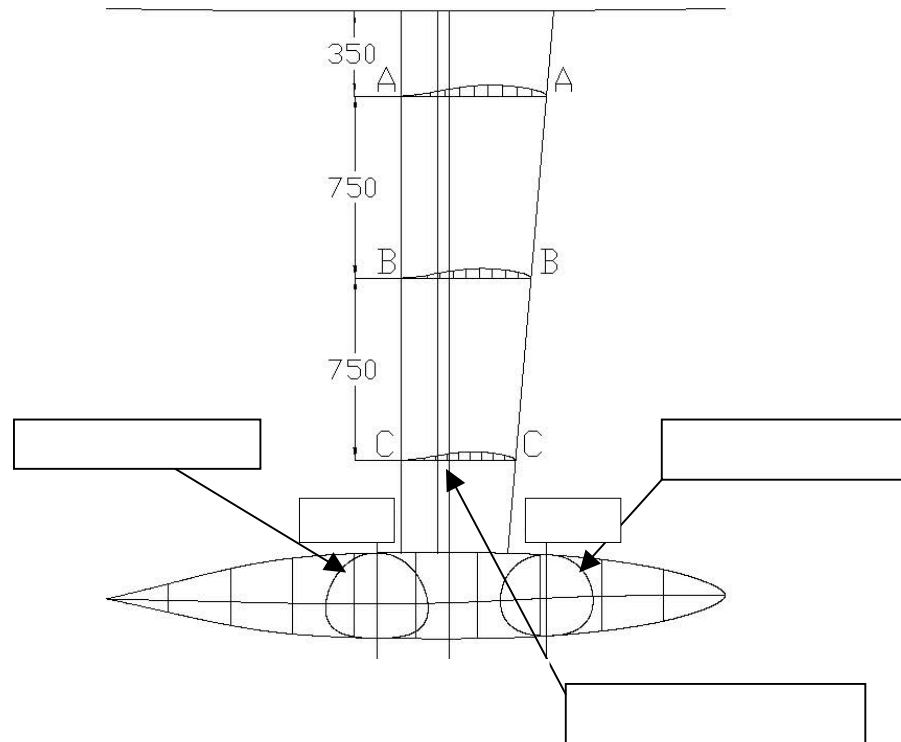

#### D.1.2 KEEL OFFSETS

Table D keel and bulb offsets (bulb offsets are at maximum breadth).

Section	Chord length	100%	90%	80%	70%	60%	50%	40%	30%	20%	10%
<b>A-A</b>	599	0.6	5.8	14.0	24.8	35.3	42.6	45.7	44.2	38.3	28.3
<b>B-B</b>	536	0.6	5.0	12.0	21.3	30.6	37.3	40.4	39.2	34.0	24.8
<b>C-C</b>	473	0.6	4.4	10.2	17.8	26.1	32.3	35.2	34.3	29.7	21.5
Bulb m-b	2550	0/73	116	160	191	208	214	210	194	160	109

# Appendix E

## E.1 Rudder

### E.1.1 RUDDER DIAGRAM + TEMPLATE POSITIONS

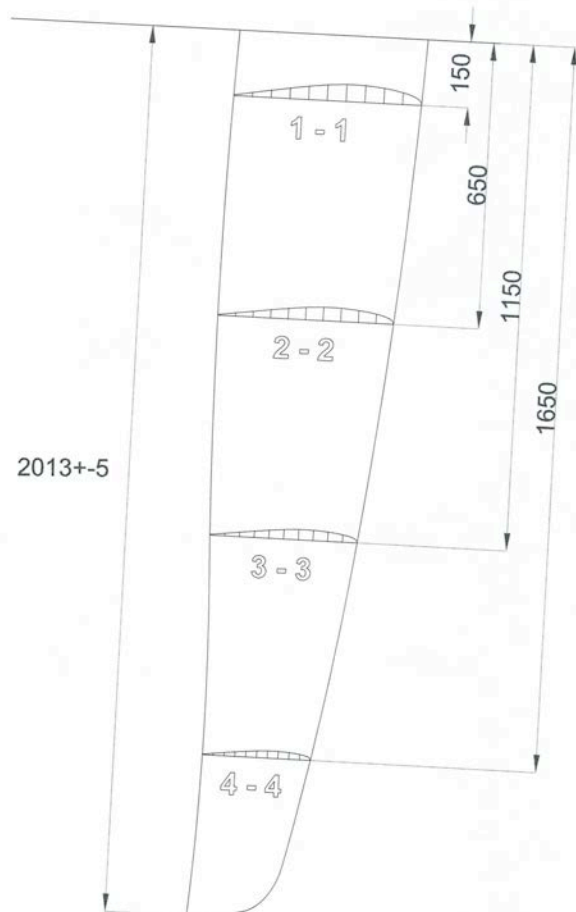

### E.1.2 RUDDER OFFSETS

Table E

Section	Chord length	100%	90%	80%	70%	60%	50%	40%	30%	20%	10%
1-1	423	0.75	8.0	16.3	23.3	29.8	35.0	37.9	37.5	33.8	26.1
2-2	396	0.75	7.4	13.1	18.7	23.8	28.0	30.4	30.1	27.2	21.1
3-3	332	0.75	5.8	10.1	14.2	18.0	21.2	23.1	23.0	20.9	16.4
4-4	244	0.75	4.2	7.2	10.0	12.7	14.9	16.2	16.2	14.8	11.8

All dimensions are in mm and are the minimum allowed

## Appendix F

### F.1 RIGGING

#### F.1.1 POSITION ON DECK OF MAST AND SHROUDS

FMP2 is located over FMP1 at the deck level  
See pictures on RC 44 Measurement Manual

## Appendix G

### G.1 CLASS INSIGNIA

#### G.1.a Shape, colors and dimensions of the Class Insignia

**Faltan parámetros necesarios o son incorrectos.**

#### G.1.b Position on sail of the Class Insignia:

- (a) Centerline of the insignia between 4<sup>th</sup> and 5<sup>th</sup> batten from the foot of the mainsail (equal distance from the 4<sup>th</sup> and 5<sup>th</sup> batten).
- (b) The two stickers shall be positioned back to back, with the “FORTY 44 FOUR” wording on the starboard side of the sail.

## Appendix H – HARDWARE AND FITTINGS

*The lists hereafter will be periodically updated to follow manufacturer's catalogues evolution.*

*The updated lists is published on the RC 44 website: [www.rc44.com](http://www.rc44.com)*

*Any item listed in Appendix H shall be on board on its designed position. Adding extra items is not allowed.*

### H.1 ASSEMBLED HULL

<b>DECK HARDWARE HARKEN-SPINLOCK</b>		
<b>Main</b>		
R32.1.8m	1	Big Boat track low-beam
T3243B.HL	1	Big Boat Car with Standup, MWL:2041Kg, BL:4081Kg
H3169	1	Big Boat End Control double sheave (pair) MWL:408Kg, BL:1040Kg
H2650	1	Carbo block single/fixe for 6:1 MWL:220Kg, BL:735kg
H3231	1	Black Magic block, single, swivel 75mm MWL:2268Kg, BL:4536Kg
custom	1	custom Sheave Box
H754	1	Hi-Load Sheave
H3236	1	Footblock single/lockoff MWL: 2380Kg, BL: 4762Kg
H468	1	Micro Cam-Matic MWL:91Kg, BL:181Kg
H3234	1	Footblock single MWL:2380Kg, BL:4762Kg
H096	2	Bullet Upright MWL:136Kg, BL:907Kg
H150	2	Cam-Matic MWL:136Kg, BL:340Kg
H425	2	Standard Fairlead

<b>Jib</b>		
G2747B	2	Genoa Lead Car Midrange, Ball Bearing MWL:1043Kg, BL:2268Kg
R27.1.8mt	1	Midrange track, low-beam
H1631	1	Midrange end control, single sheave (pair) MWL: 159Kg, BL: 397Kg
E2700	2	End stop
H1515	1	Double control block (pair) MWL:272Kg, BL:907Kg
H287	8	Bullet block Thru-deck MWL:136Kg, BL:907Kg
H459	4	Cam-Matic with Fairlead MWL:136Kg, BL:340Kg
H082	2	Bullet block MWL:136Kg, BL:907Kg
H340	4	Carbo block MWL:150Kg, BL:454Kg, for extra control line purchase
<b>J2-6° Sheeting</b>		
Custom	2	Hard anodized thimble
H754	2	Hi load sheave
Custom	2	Custom carbon sheave box
H3223	3	Black Magic Teardrop/HL MWL: 1134kg, BL:2268kg
H6065	2	57mm Padeye block, MWL: 850kg, BL: 1900kg
H343	2	29mm Carbo block Double/swivel with becket MWL: 229kg, BL: 737kg
H344	2	29mm carbo block triple/swivel MWL:449kg BL:907kg
H348	2	29mm Carbo block, single fixed, MWL:150, BL: 454kg

<b>Jib Cunnigham</b>		
Custom	1	Custom forestay shuttle provided by Pauger
Custom	1	Custom carbon sheave box
Custom	3	High Load sheave
H3223	2	57mm Black Magic Teardrop block MWL:1134kg BL:2268kg
H343	1	29mm Carbo block double/swivel MWL:229 kg, BL: 737kg
H344	1	29mm Carbo block triple/swivel, MWL: 449kg BL: 907kg
H340	1	29mm carbo block single/swivel, MWL:150kg BL:454kg
H150	1	Standard Cam-matic cleat, MWL: 136kg BL:340kg
		<b>The jib cunnigham purchase shall be attached to the forestay ram</b>
<b>Halyards</b>		
H1990	3	Mastbase block/fixed SWL:2273Kg, BL:4545Kg
Stopper	1	Spinlock XTS (6-8mm)
Stopper	2	Spinlock XX
H3215	1	Black Magic single block 57mm HL MWL :1134Kg, BL :2268Kg
<b>Vang</b>		
H2650	1	Carbo block 40mm single/fixed MWL:220Kg, BL:735Kg
H2636	1	Carbo block 40mm single/swivel MWL:220Kg, BL:735Kg
H131	1	Big Bullet block, thru-deck, MWL: 136Kg, BL: 907Kg
H140	1	Big Bullet, pivoting exit/150, Cam-Matic, MWL: 136Kg, BL: 907Kg
H2152	2	Carbo block 57mm MWL:359Kg, BL:1080Kg
<b>Spinnaker</b>		
H3214	2	Single loop block MWL:1134Kg, BL:2268Kg
H3220	2	Footblock, single/high-load MWL : 1134Kg, BL : 2268Kg
Custom	4	Pauger design 50mm sheaves in carbon housing
Custom	2	Custom carbon in line exit
H2606	2	Carbo block 57mm cheek MWL:360Kg, BL:1080Kg
Stopper	2	Spinlock XTS 6-10mm
H2606	1	Carbo block 57mm cheek MWL:360Kg, BL:1080Kg
H1500	1	deck organizer
H2133	1	Eyestraps
H134	1	Big Bullet block, in-line exit MWL:272Kg, BL:907Kg
H150	2	Cam-Matic MWL:136Kg, BL:340Kg
H459	1	Cam-Matic with EX Fairlead MWL 136Kg, BL 340Kg
Custom	1	Black anodized aluminium tack line bowsprit end fitting
Custom	1	Custom carbon in line exit
Stopper	1	Spinlock XTS 8-14mm
<b>Retriever</b>		
H754	2	Sheave
Custom	2	Custom Sheave Box
H2152	2	Carbo block, 57mm MWL: 359Kg, BL: 1080Kg
H2601	1	Carbo block, single, becket 57mm MWL: 359Kg, BL: 1079Kg

<b>Backstay</b>		
Custom	2	Custom high load block in custom carbon sheave box
Custom	2	High load sheave in custom aluminum casing or 75mm Black Magic Single Loop Block H3230
Custom	2	High load sheave in custom aluminium casing
Custom	2	Custom carbon in line exit
Tylaska	2	TYL-T8 LB or similar
Stopper	2	Spinlock XTS 8-14mm
2606	2	57mm Carbo block cheek MWL 360 kg, BL: 1080Kg
<b>Forestay</b>		
Custom	1	Sheave
Custom	1	Custom carbon Sheave Box
Custom	4	Sheaves with carbon sheave boxes
Custom	1	Forestay gauge
<b>Cunningham</b>		
H408	1	Triple block 16mm MWL:318Kg, BL:544Kg
H407	1	Double block, becket, 16mm MWL:204Kg, BL:544Kg
H082	1	Bullet block, single, MWL:136Kg, BL:907Kg
H113	2	Bullet block, pivoting cheek MWL:136Kg, BL:907Kg
H287	2	Bullet block Thru-deck MWL:136Kg, BL:907Kg
H150	2	Cam-Matic MWL:136Kg, BL:340Kg
H375	2	X-Treme Angle Fairlead
H2650	1	Carbo block 40mm single/fixed MWL:220Kg, BL:735Kg
H2636	1	Carbo block 40mm single/swivel MWL:220Kg, BL:735Kg
<b>Checkstay adjuster</b>		
Custom	2	Custom hard anodized thimbles
Custom	2	Custom through mast fittings
H2600	2	57mm carbo block single/swivel, MWL:360, BL: 1080kg
H306	1	Through deck block MWL:680kg, BL1361kg
H2636	3	40mm carbo block, single/swivel, MWL: 220kg, BL:735kg
<b>TrimTab</b>		
Custom	8	Custom carbon Micro Footblock
H421	2	16mm, Thru-deck, MWL: 113Kg, BL: 544Kg
H468	2	Micro Cam-Matic MWL:91Kg, BL:181Kg
H424	2	Micro Fairlead
H404	2	16mm Block MWL 113Kg
H082	2	Bullet block, single, MWL:136Kg, BL:907Kg
Custom	10	Sheaves with carbon sheave boxes
Custom	2	Trim tab gauge
Custom	1	Stainless steel trim tab shaft (as supplied by manufacturer)
Custom	1	Carbon lever arm (anchor point at 700mm from pivot point)
Custom	2	Carbon slider for gauge system (Length=870mm from end-stopper to end-stopper)

<b>Outhaul</b>		
H082	1	Bullet block, single, MWL:136Kg, BL:907Kg
H113	2	Bullet block, pivoting cheek MWL:136Kg, BL:907Kg
H287	2	Bullet block Thru-deck MWL:136Kg, BL:907Kg
H150	2	Cam-Matic MWL:136Kg, BL:340Kg
H375	2	X-Treme Angle Fairlead
H1559	1	Midrange fiddle, MWL: 816Kg, BL: 2268Kg
H1560	1	Midrange fiddle/becket, MWL: 816Kg, BL: 2268Kg
H3243	1	Black Magic block 75 mm single/swivel MWL:1361Kg, BL: 2722 Kg
H2650	1	Carbo block 40mm single/fixed MWL:220Kg, BL:735Kg
H2636	1	Carbo block 40mm single/swivel MWL:220Kg, BL:735Kg

		<b><i>WINCH SYSTEM HARKEN</i></b>
<b>Winches</b>		
F 84426800	1	B55.3 STR UD - Main sail winch
F 84517400	2	B530 TCR UD - Primary winch
F86528300	2	B44.2 STA – Halyard winch With W.45 Racing Drum
F 84347100L	2	Bevel Gear Box - LH
F 84347000	1	Bevel Gear Box - RH
PEDxxxByyy Czz	1	Pedestal tube description as per drawing NEW
H468	2	Micro Cam-Matic SWL:91Kg, BL:181Kg
H424	2	Micro Fairlead
H421	1	16mm, Thru-deck, SWL: 113Kg, BL: 544Kg
F436010062	1	Pedestal belt as per drawing 42050
F 842375 40	1	605 Tbox 2 disc., ped. Mounted, one disc. At other side
F 842650 00	2	Aluminium pedestal handle
F 842260 00	3	Disconnect button 120
E423890050	6	Aluminium drive shaft
A 42230 00	3	End flange upper plus stud screw
A94223100	3	End flange lower plus stud screw
A 39780 00	3	Straight coupling adapter 21-30
A 42395 00	3	Straight coupling 30/30 L=45
A423930052	3	Straight coupling 25/30 L=45
S404750080	9	Clip 25
A 74047400	6	Spherical outer to 30-spline
S427430004	6	Nut 25 HL
F84235700	1	OVERDRIVE SYSTEM FOR PRIMARY WINCHES
B8SG	5	Ball Bearing Aluminium Winch Handle (B8SG from Harken or 8"/200mm OneTouch Power Grip from Lewmar)

<b>MAST &amp; RIGGING</b>		
<b>General Rig</b>		
	1	Variable section upper mast profile-prepreg carbon
	1	Variable section lower mast profile-prepreg carbon
	1	Boom-prepreg carbon
	6	Spreader-prepreg carbon
	3	CNC machined hard anodized Al spreader bar
	4	CNC machined titanium mast junction washer plates
	72	10.9 M8x20 mast junction bolts
	1	Custom carbon/aluminum gooseneck
	2	Custom 20mm mast foot plate
	1	Custom carbon rigid vang with internal purchase
	1	Retractable/pivoting bowsprit-prepreg carbon
<b>Hydraulic system</b>		<i>Old Holmatro items with identical references are allowed</i>
25933	1	Forestay ram, HCL-10B black anodizes cylinder - Reckmann
26489	1	HCP11C, Control panel – Reckmann, max pressure 440 Bars
27343	1	Hose MH7,5 – Reckmann
28096	1	Hydraulic oil – Reckmann
27259	1	Mastjack set HMJ20 - Reckmann
<b>Standing rigging</b>	1	Forestay PBO – supplier Future Fibers (FF)
	2	Backstay – Dyneema SK75, supplier Gottifredi Maffioli
	2	D1- PBO Shroud (Length=473mm; Diameter=10mm; BL=8,700kg), FF
	2	VD2-PBO Shroud (Length=954mm; Diameter=8mm; BL=5.300kg), FF
	2	VD3- PBO Shroud (Length=1361mm; Diameter=8mm; BL=5.300kg), FF
	2	VD4- PBO Shroud (Length=1730mm; Diameter=10mm; BL=8.700kg), FF
	4	Custom carbon chain plates

- Lashing the forestay or forestay strop on a fix point is not allowed. The forestay strop shall be attached to the ram fork only.

- The length of the forestay strop shall be minimum 2500 mm

<b><i>RUNNING RIGGING SPECIFICATION</i></b>					
<i>No.</i>	<i>Art.</i>	<i>Rope</i>	<i>Cover</i>	<i>Diameter (minimum)</i>	<i>BL (kg)</i>
<b>Sheets</b>					
1	Main sheet	Dyneema	yes	10mm	5920
2	Jib sheets	Dyneema	yes	10mm	5920
3	Spinnaker sheets	Dyneema	yes	8mm	3950
<b>Halyards</b>					
4	Main halyard	Dyneema	yes	8mm	3950
5	Jib halyard	Dyneema	yes	8mm	5920
6	Spinnaker halyard	Dyneema	yes	8mm	3950
<b>Ropes - Deck / Mast</b>					
7	Backstay	Dyneema	yes, PBO	10mm	5920
8	Genoa purchase	Dyneema		5mm	1530
9	Genoa control line	Dyneema	yes	7mm	
11	Main traveler	Dyneema	yes	6,5mm	
12	Tack line	Dyneema	yes	8mm	3950
13	Bowsprit control	Dyneema	yes	8mm	3490
14	Bowsprit out	Dyneema	yes	8mm	2100
15	Bowsprit stopper	Dyneema	Core only	4mm	1850
16	Trim tab control	Dyneema	yes	4mm	980
	Trim tab purchase	Dyneema	Core only	3mm	
17	Steering system	Dyneema	Core only	6mm	3950
18	Quadrant stopper	Dyneema	Core only	4mm	1850
19	Short sheets - genoa1	Dyneema	Core only	5mm	2790
20	Deck tension	Dyneema	Core only	6mm	3950
21	Lashing	Dyneema	Core only	3mm	900
22	Cunningham-purchase	Dyneema	yes	5mm	1020
23	Cunningham-sail	Dyneema	Core only	5mm	2790
24	Cunningham-regulation	Dyneema	yes	6mm	1530
25	Outhaul-end boom	Dyneema	Core only	8mm	7400
26	Outhaul-in boom	Dyneema	Core only	6mm	3950
27	Outhaul-purchase	Dyneema	yes	6mm	1530
28	Outhaul-regulation	Dyneema	yes	6mm	1530
29	Outhaul-end boom - loop	Dyneema	Core only	6mm	3950
31	Check stay - end block	Dyneema	Core only	4mm	1850
32	Check stay - purchase	Dyneema	Core only	5mm	2790
33	Check stay - purchase	Dyneema	yes	6mm	1530
34	Check stay - regulation	Dyneema	yes	6mm	2790
35	Drop-line spinnaker	Dyneema	yes	8mm	3490
36	Elastic rope			6mm	
51	Forestay strop	Dyneema	May be covered	14mm	10830
52	Runner strops	Dyneema	May be covered	10mm	5920
<b>Inbord sheeting</b>					
37	First cascade	Dyneema	Core only	6mm	3950
38	Second/third cascade	Dyneema	Core only	5mm	2790

39	Regulation	Dyneema	yes	6mm	1530
	<b>Jib cunningham</b>				
41	Jib cunn. - tack line	Dyneema	yes	6mm	3950
43	Jib cunn. - lashing	Dyneema	Core only	4mm	2790
44	Jib cunn. - purchase	Dyneema	yes	6mm	1530
45	Jib cunn. - regulation	Dyneema	yes	8mm	2100
	<b>Shackles</b>				
47	TYL-T8 SB	T 8 Shackle Standard Bail		Spi + Jib Halyard	
48	TYL-H8	H 8 Halyard Shackle		Main Halyard	
49	TYL-T8 SB	T 8 Shackle Standard Bail		Tack line	
50	TYL-T5 SB	T 5 Shackle Standard Bail		Short sheet	

**Definitions:**

- All line shall meet minimum breaking load and minimum diameter stated above.
- Minimum rope size applies to the outside diameter of a covered rope (if a covered is indicated in the table above). There is no minimum length for the lines
- Any material is allowed for the cover, except PBO, unless stated in the table above
- Stripping is allowed
- For the item 51 and 52 the minimum diameter applies to the core only.

<b><i>STEERING SYSTEM JEFA-RIBA</i></b>		
<b>Part No.</b>	<b>Quantity</b>	<b>Description</b>
BS25-15	2	Bulkhead steerer-Jefa
CH5860	2	Chain assembly-Jefa, length: 605mm
AS140or5BT140	1	Lower bearing-Jefa
SLE140AL	1	Lower sleeve-Jefa
Gaiter	1	Sealing Kit for lower bearing-Jefa
4S100Z	1	Upper bearing-Jefa
SLE100AL	1	Upper sleeve with emergency tiller fitting-Jefa
EM42060Z	1	Al emergency tiller-Jefa
Custom	4	Carbon sheave box with sheave
Custom	2	Carbon steering pedestal-RiBa
Custom	2	Carbon steering wheel-RiBa
Custom	1	Carbon steering quadrant with safety system

<b><i>ELECTRONICS B&amp;G</i></b>		
<b>Part No.</b>	<b>Quantity</b>	<b>Description</b>
BGH300002	1	H3000 Hercules race base pack ( include one gfd on base coffee grinder)
BGH270001	5	Hercules 20/20 display (5 unit on mast rack )
BGH030002	1	Vertical wind sensor 1.04 meter
SEN-SPD-HPF	1	Speed sensor
SEN-DPT-HPF	1	Depth sensor
486-00-009	1	Compass sensor
690-00-004	1	Heel sensor
RRF-ACP	2	Rudder angle and trim tab angle sensor
	1	NMEA GPS device
	1	Vhf hand set radio station

Use of the electronic devices while racing:

- a) Logging data on an appropriate device is allowed
- b) The transmission or reception of data is forbidden
- c) The use of any device that is not listed in Appendix H Electronics is not allowed with the exception of point a) above. This includes load cell, Velocitek or any similar type of products.

<b><i>PROPULSION SYSTEM VOLVO</i></b>		
D1-20	1	Volvo inboard diesel engine (20HP)
	1	Volvo engine control panel
	1	Spinlock remote control
	1	S.S. fuel tank (16l)
	1	Hydraulic oil pump
	1	Plate heat exchanger for hydraulic oil
	1	S.S. hydraulic oil tank
	1	Retractable S.S. hydraulic SailDrive unit
	1	Fixed fthree blade propeller
	2	Up/down hydraulic ram
	1	Volvo up/down electro-hydraulic pump
	1	Volvo up/down remote control panel
	1	Exhaust system
<b><i>ELECTRIC SYSTEM</i></b>		
	1	<b>Lithium-ion batteries are not allowed</b>
	1	Electric control panel
	1	Main switch

<b><i>PLUMBING</i></b>		
	1	Hand bilge pump - operated from cockpit
Minimum	2	Electric bilge pump with automatic switch
	2	Drainage fittings in the hull (for the boat on cradle)

**Bilge pump outlet details: there is a maximum of two bilge pumps outlet at each side of the hull, about mid-ship. The internal diameter of the hole cannot exceed 15mm, if two holes are present, the minimum distance between the holes is 100mm, and no hole shall be at less than 100mm from the sheerline.**

Effective Date : 20.03.2016